



# Medical Stretchers & Attendant Seats







## Medical Stretchers

**Description:** Our stretcher kits provide a King Air operator with the option of transporting an ill or injured patient. These stretchers are ideal for the operator who doesn't need critical care medical equipment. Kit includes stretcher unit and cover, Ferno model 12-C portable aero (folding) litter, mattress, mattress cover (conforms to FAR 23.853 horizontal flame test), restraint system, installation instructions, and weight and balance data, etc. Illustration shows Ferno model 12-1 aero litter with adjustable backrest.

**Models:** Beechcraft King Air 90, 100, 200, 300, 350, 350i

**STC NUMBER:**

<b>U.S. FAA</b>	SA2671CE	200, 300 (350) series (except 350i)
	SA2672CE	99, 100 series
	SA2673CE	65, 80, 90 (except F90) series
	SA2674CE	F90
<b>EASA</b>	IM89-SI-0009	(France) 200, 300 (350) series (except 350i)
	IM19-SI-0001	(France) 99 series
	IM72-SI-0001	(France) 100 series
	IM20-SI-0011	(France) 65, 80, 90 (except F90)
	IM132-SI-0001	(France) F90
<b>INDIA:</b>	07-11/07-RD(Part-I)	B200, C90
	07-11/2007-AED (Vol-IV)	B200GT

**Features:** Kit includes FAA approved mattress with removable cover. All materials conform to FAA flame testing standards.

**Installation:** No airframe modification is required other than removing existing seats and furnishings from the desired location and setting the new stretcher assembly in the existing seat track (complete installation instructions, diagrams, and weight and balance data are included in the kit). The stretcher can be installed on either side of the airplane in a range of stations.

**Lead Time:** Stretchers are normally in stock and available for immediate world-wide shipment, however, fluctuations in demand may cause up to a 30 day delivery delay.





## **Installed King Air Medical Stretcher**





## Medical Stretcher Line Drawing

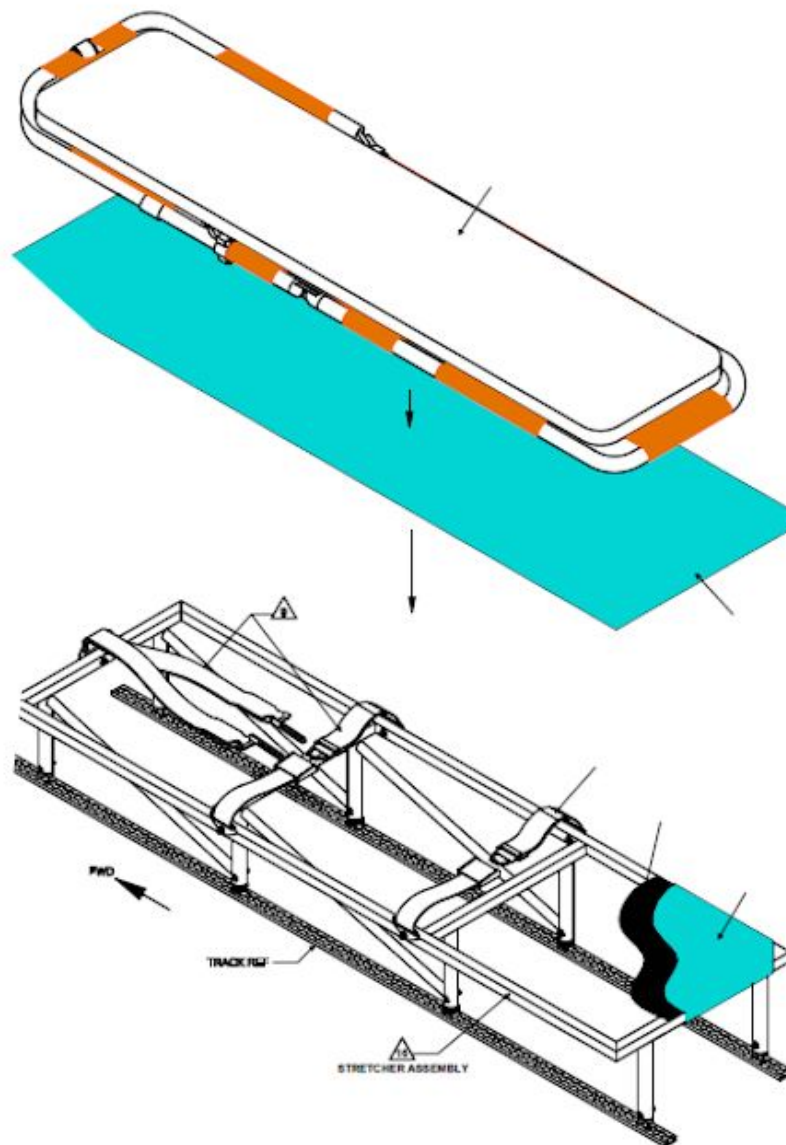



## 4-Place Stretcher-Divan







# Stretcher-Divans

**Description:** Increase the utility and functionality of your King Air with an AvFab 4 place Divan/Stretcher that allows you the option of carrying either passengers or a patient on the same divan. This conversion can easily be done with the divan/stretcher still in the aircraft. The Divan/Stretcher is approved for occupancy during all phases of flight (including takeoff and landing).

See more at <http://avfab.com/king-air-100-200-300-90-stretcher-divan-4-place-rh>

**Models:** Beechcraft King Air 90, 100, 200, 300, 350, 350i

**FAA / STC:** Covered by one or more of the following:  
SA2630CE, SA2631CE, SA2632CE, SA2633CE

**Options:** Under seat storage drawers.  
Shoulder harness kit (required for this installation).

**Features:** Very quickly and easily converted between passenger carrying and for patient transportation. You can carry passengers on one leg of a flight and then convert it for an ambulatory person on the next leg. FAA approved for either use.

**Installation:** No airframe modification is required to install the divan other than removing existing seat/s and furnishings, and locating the new divan in the desired location (complete installation instructions, diagrams, and weight and balance data are included in the kit). AvFab shoulder harness restraint system, part number 32-0181K, is required to install these divans. See shoulder harness data sheet for installation instructions. The divans can be installed on either side of the airplane in a range of stations.

**Lead Time:** Typical lead time for these divan/stretchers is 14 days after receipt of purchase order. However, fluctuations in demand may cause up to a 30 day delivery delay



## Installed 4-Place Stretcher-Divan







## 4-Place Stretcher-Divan





## 4-Place Stretcher-Divan Line Drawing

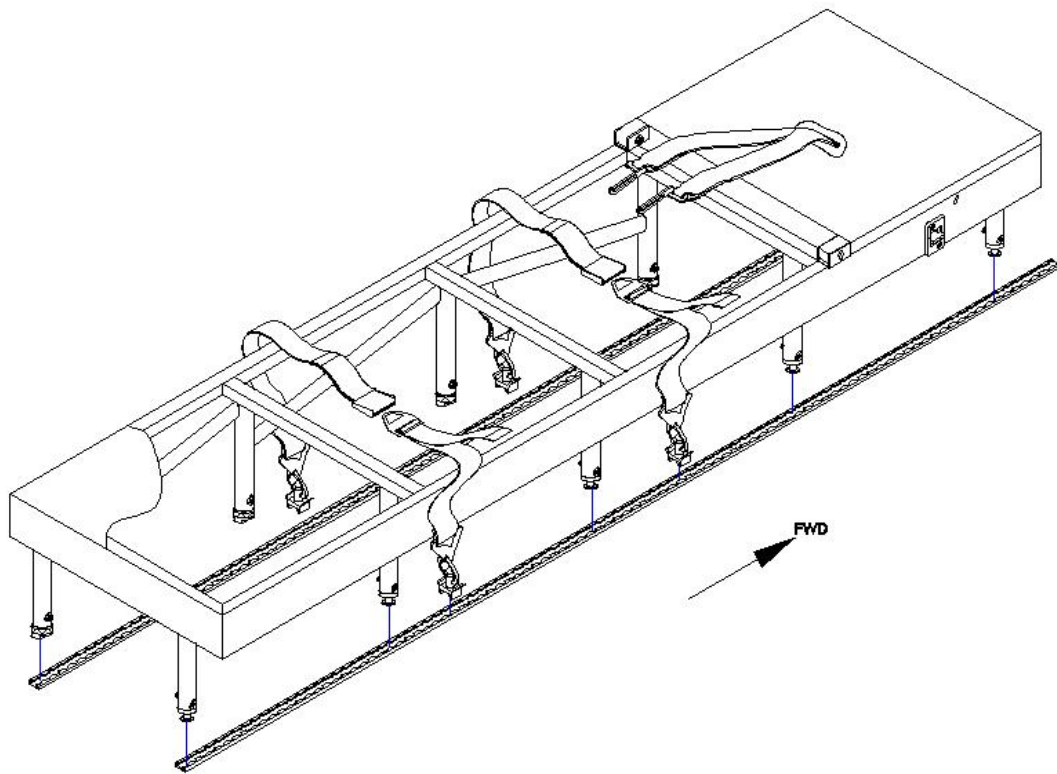

**LH ASSEMBLY WITH STRETCHER RESTRAINTS**



## Medical Attendant Seating



**2-Place  
Divan**

**2-Place  
Lateral  
Tracking  
Divan**







## Medical Attendant Seating

**Description:** Our 2-Place King Air Divan is also popular for medical attendant and Special Missions applications. In some cases you to accommodate additional passengers. Divans kits include: seat belts (TSO-C22f), track fittings, installation instructions, and weight and balance data, etc. Divan is delivered in "green" condition, without upholstery. AvFab's Two Place Lateral Tracking Divan is ideal for medical attendant use as it allows caregivers to adjust seat for closer access to patient while remaining in the restraint system.

See more at <http://avfab.com/king-air-100-200-300-350-90-2-place-divan> or <http://avfab.com/king-air-100-200-300-350-90-2-place-lateral-tracking-divan-lh>

**Models:** Beechcraft King Air 90, 100, 200, 300, 350, 350i



**FAA / STC:** Covered by one or more of the following:  
SA2630CE, SA2631CE, SA2632CE,  
SA2633CE

**Options:** Under seat storage drawers. Shoulder harness kit (required for this installation).

**Features:** Divan kits include, seat belts (TSO-C22f), track fittings, installation instructions, and weight and balance data, etc.

**Installation:** No airframe modification is required to install the divan other than removing existing seat/s and furnishings, and locating the new divan in the desired location (complete installation instructions, diagrams, and weight and balance data are included in the kit). AvFab shoulder harness restraint system, part number 32-0181K, is required to install these divans. See shoulder harness data sheet for installation instructions. The divans can be installed on either side of the airplane in a range of stations.

**Lead Time:** Typical lead time for these divan/stretchers is 14 days after receipt of purchase order. However, fluctuations in demand may cause up to a 30 day delivery delay.



## **2-Place Attendant Divan**





## Lateral Tracking 2-Place Attendant Divan







## Medical Attendant Seating Line Drawings

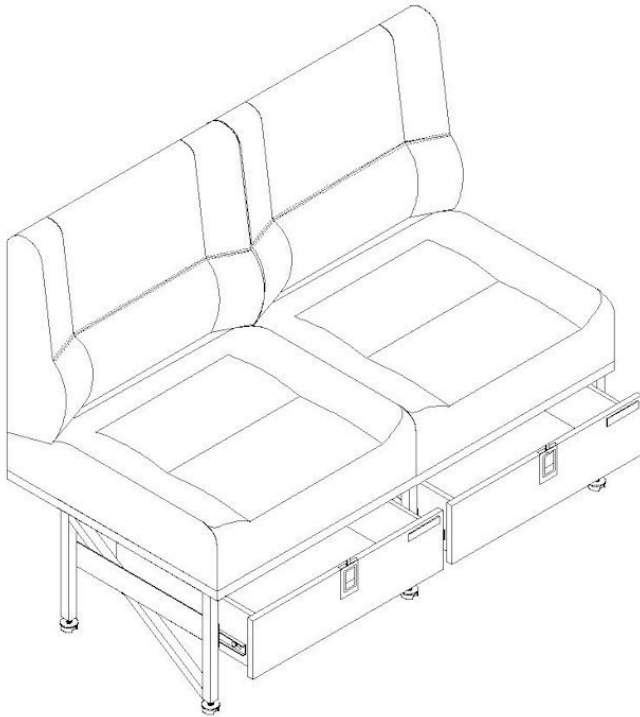

**2-Place  
Divan**

**Lateral Tracking  
2-Place  
Divan**

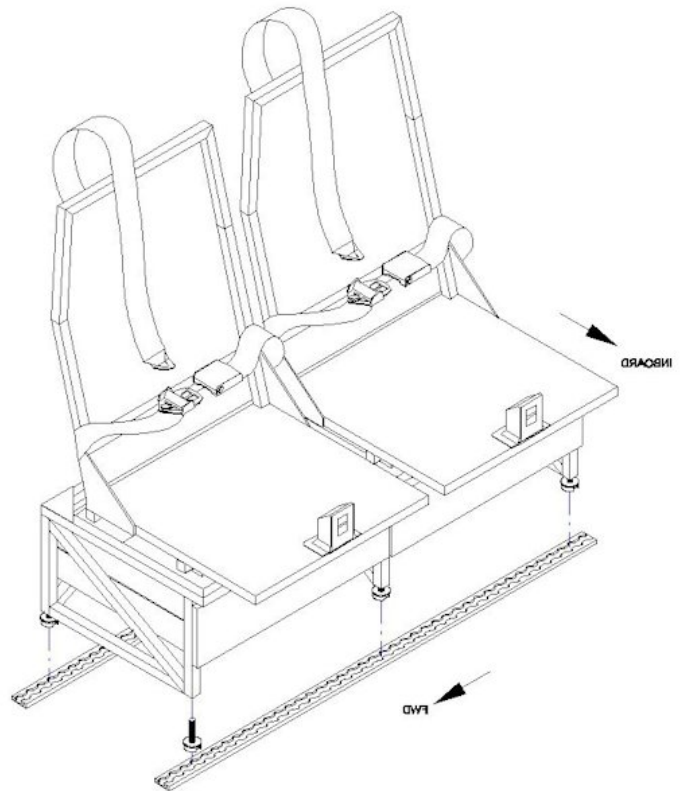



Learn more about Avfab's comprehensive line of King Air products & services at: [www.AvFab.com](http://www.AvFab.com)



**Aviation Fabricators**

805 North Forth Street

Clinton, MO 64735

(660) 885-8317

[www.AvFab.com](http://www.AvFab.com)