

# King Air DIVANS

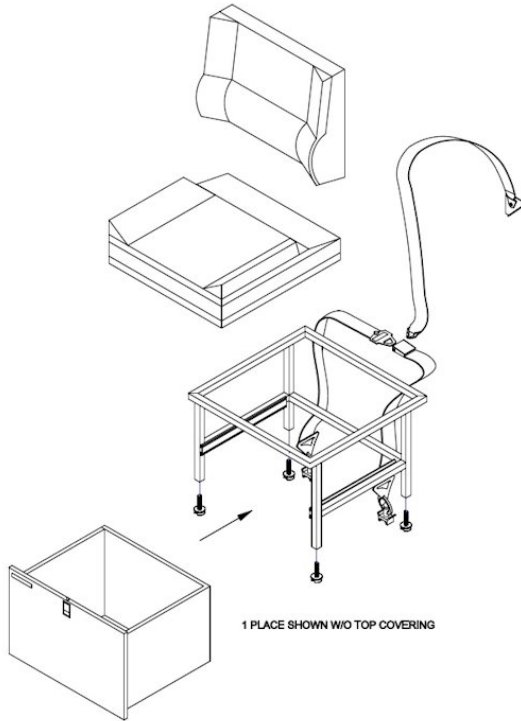

**42** YEARS OF  
AVIATION  
PASSION

# 1-PLACE DIVAN



Line Drawing shows how the seat belt harness is attached.



AvFab's 1-Place Divans were installed in a Japan Coast Guard King Air 350. This gave them the potential to accommodate additional passengers, as well as face patients that may need mid-flight care.

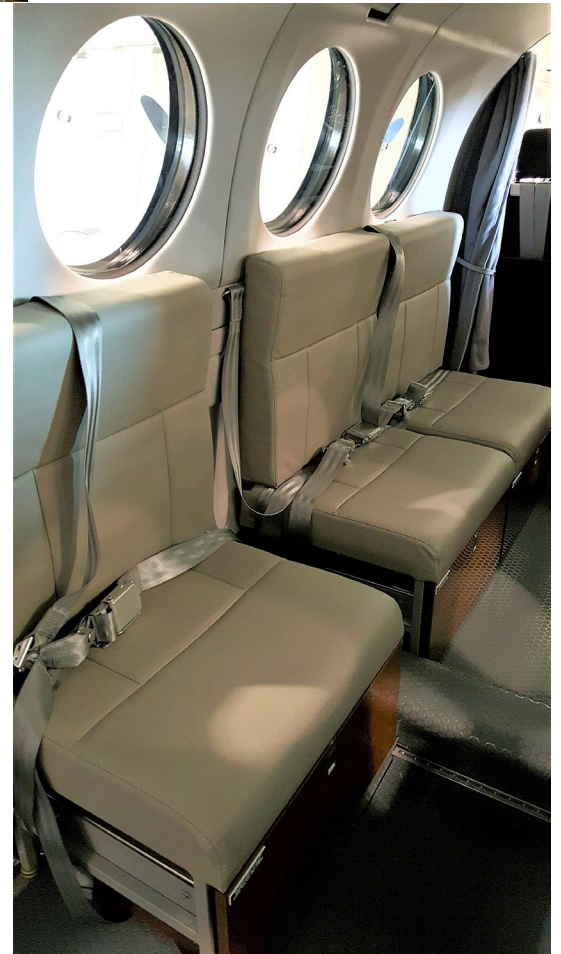

The 1-Place Divan is beneficial for Special Missions operations that provide care to onboard patients. This allows medical professionals to face the patient during flight.



**Description:** AvFab's 1-Place Divan is extremely versatile. Can be installed alone or several can be placed alongside each other. Divans provide a modern, open and comfortable atmosphere. In many cases, this will allow you to accommodate additional passengers. The Divan is delivered in "green" ready to be finished condition, without upholstery.

**Model:** All King Air Models

**Options:** Available 10-14" in height. Underseat storage drawer.

**Features:** Seat includes lap belt, life vest pouch, and cushions (un-upholstered). Various floor plans are available.

**Approvals:** Federal Aviation Administration Parts Manufacture Approval (PMA) and Supplemental Type Certificate (STC) This eliminates the need for field approval.

**STC:** SA4157SW **EASA:** 10032903 **CANADA:** M 5010-38-SA4157SW **MEXICO:** IA-371-2016 **JAPAN:** JCAB STC-179-HQT

**Installation:** No airframe modification is required to install the divan other than removing existing seat/s and furnishings, and locating the new divan in the desired location (complete installation instructions, diagrams, and weight and balance data are included in the kit). There are instances where a shoulder harnesses will be mounted to the sidewall of the airplane. This is dependent on the serial number of the airplane and will be assessed by AvFab's engineering team. The Divans can be installed on either side of the airplane in a range of stations. Typical installed divan weight is 18 pounds. If under seat storage drawer is required, 23 pounds should be expected.



1-Place Divans also have side by side versatility.

# 1-PLACE SIDE FACING SEAT



\*Optional Ice Tank Shown\*



**Description:** AvFab's 1-Place King Air Side Facing Seat is extremely versatile. The seat is approved for passengers during all stages of the flight including take-off and landing. The included shoulder harness adds a margin of safety over the OEM seat. AvFab's Side Facing seat has a more modern appearance and is more comfortable because it has a larger seating surface than the OEM seat. Seat is delivered in "green" ready to be finished condition, without upholstery.

**Model:** All King Air Models

**Options:** Underseat storage drawer, Ice Tank.

**Features:** Seat includes lap belt, life vest pouch, and cushions (un-upholstered). In the 90 series, it allows for the RH side forward facing seat to recline. Various floor plans are available.

**Approvals:** Federal Aviation Administration Parts Manufacture Approval (PMA) and Supplemental Type Certificate (STC) This eliminates the need for field approval.

**STC:** SA4157SW **EASA:** 10032903 **CANADA:** M 5010-38-SA4157SW **MEXICO:** IA-371-2016 **JAPAN:** JCAB STC-179-HQT

**Installation:** No airframe modification is required other than removing existing seat/s and furnishings, and putting the new 1-Place Seat in the desired location (complete installation instructions, diagrams, and weight and balance data are included in the kit). There are instances where a shoulder harnesses will be mounted to the sidewall of the airplane. This is dependent on the serial number of the airplane and will be assessed by AvFab's engineering team. The seat can be installed on either side of the airplane in a range of stations. Seat legs are 12 inches in height and the weight is 18 pounds. Optional Drawer will add 5 pounds. Optional Ice Tank will add 3 pounds.

# 2-PLACE DIVAN

AvFab's 2-Place Divan comfortably allows for two people to face inboard. Our 2-Place Divans are the only STC approved option that can be occupied during all phases of the flight, including take-off and landing.



# 2-PLACE ATTENDANT DIVAN



AvFab's 2-Place Attendant Divan allows for two medical professionals to face the patient mid-flight, perfect for Special Mission applications. In some cases this could allow for an additional passenger. Our 2-Place Divans are the only STC approved option that can be occupied during all phases of the flight, including take-off and landing.



# 2-PLACE LATERAL TRACKING DIVAN

AvFab's 2-Place Lateral Tracking Attendant Divan takes the extra step toward patient safety, allowing for the medical attendant to utilize the tracking seat base and be in closer proximity to the patient, while the aircraft is in motion.

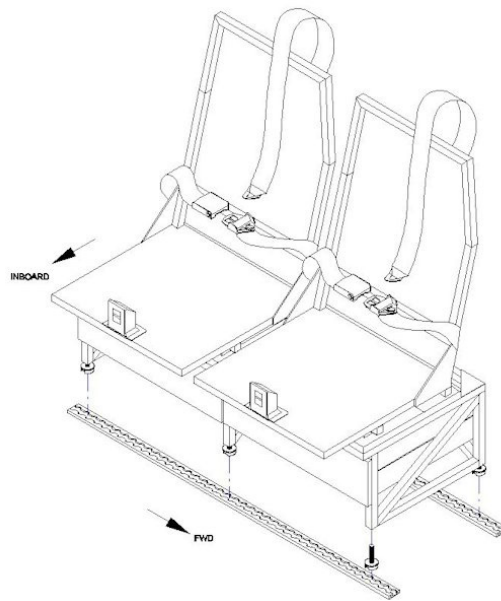



**Description:** AvFab's 2-Place Divan allows for two passengers, making a more modern and open layout in the cabin. All of the options are STC approved for all stages of flight including take-off and landing. Our 2-Place Divan is also popular for medical attendant and Special Missions applications. In some cases it allows you to accommodate additional passengers. Divans kits include: seat belts (TSO-C22f), track fittings, installation instructions, and weight and balance data, etc. Divan is delivered in "green" ready to be finished condition, without upholstery. AvFab's 2-Place Lateral Tracking Divan is ideal for medical attendant use as it allows caregivers to adjust seat for closer access to patient while remaining in the restraint system.

**Model:** All King Air Models

**Options:** Close-Out Panels, Drawers, Lateral Tracking, Upholstery

**Features:** Divan kits include, seat belts (TSO-C22f), track fittings, installation instructions, and weight and balance data, etc.

**Approvals:** Federal Aviation Administration Parts Manufacture Approval (PMA) and Supplemental Type Certificate (STC). This eliminates the need for field approval.

**STC:** SA4157SW **EASA:** 10032903 **CANADA:** M 5010-38-SA4157SW **MEXICO:** IA-371-2016 **JAPAN:** JCAB STC-179-HQT

**Installation:** No airframe modification is required to install the divan other than removing existing seat/s and furnishings, and putting the new divan in the desired location (complete installation instructions, diagrams, and weight and balance data are included in the kit). There are instances where a shoulder harnesses will be mounted to the side-wall of the airplane. This is dependent on the serial number of the airplane and will be assessed by AvFab's engineering team.

# 3-PLACE DIVAN

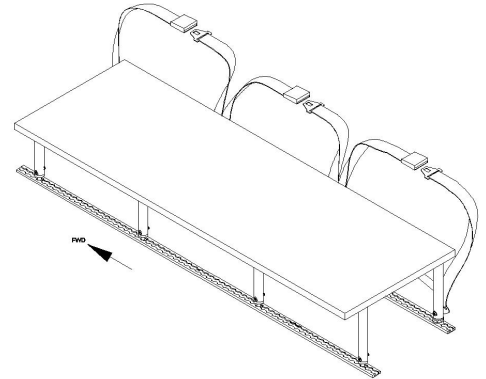
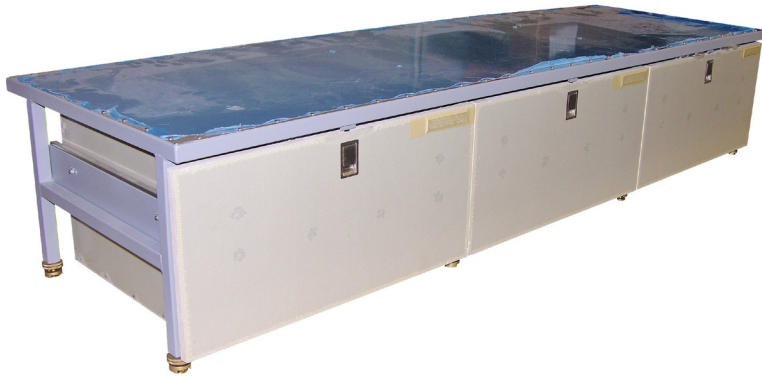

AvFab's 3-Place Divan, is an easy way to add additional seating, while giving the cabin a more modern look to your King Air. The shown optional drawers allow for underseat storage capabilities.

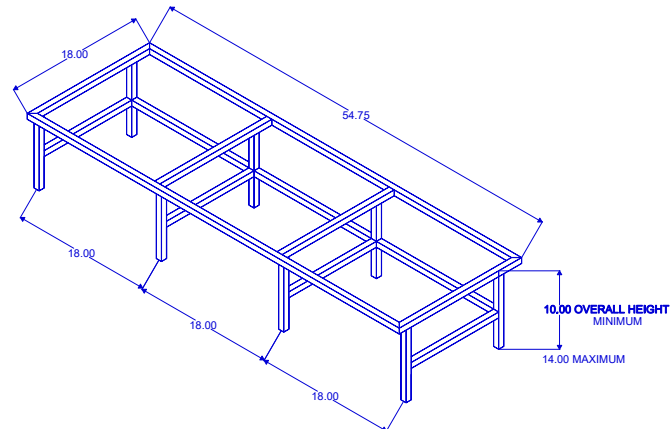

**Description:** AvFab's 3-Place Divan allows for three passengers in all stages of the flight including take-off and landing. Our 3-Place Divan makes a more modern and open layout in the cabin. Divans kits include: seat belts (TSO-C22f), track fittings, installation instructions, and weight and balance data, etc. Divan is delivered in "green" ready to be finished condition, without upholstery.

**Model:** All King Air Models

**Options:** Storage Drawers, Shoulder Harness Kit

**Features:** Divan kits include, seat belts (TSO-C22f), track fittings, installation instructions, and weight and balance data, etc.

**Approvals:** Federal Aviation Administration Parts Manufacture Approval (PMA) and Supplemental Type Certificate (STC). This eliminates the need for field approval.

**STC:** SA4157SW **EASA:** 10032903 **CANADA:** M 5010-38-SA4157SW **MEXICO:** IA-371-2016 **JAPAN:** JCAB STC-179-HQT

**Installation:** No airframe modification is required to install the divan other than removing existing seat/s and furnishings, and putting the new divan in the desired location (complete installation instructions, diagrams, and weight and balance data are included in the kit). There are instances where a shoulder harnesses will be mounted to the sidewall of the airplane. This is dependent on the serial number of the airplane and will be assessed by AvFab's engineering team.

# 4-PLACE DIVAN



The stretcher/divan quickly and easily converts between passenger and patient configurations. You can carry passengers on one leg of a flight and then convert it for an ambulatory person on the next leg. Occupancy in either configuration is FAA-approved during all phases of operation.



**Description:** AvFab's 4-Place Divan allows for four passengers in all stages of the flight including take-off and landing. Our 4-Place Divan makes a more modern and open layout in the cabin. Divans kits include: seat belts (TSO-C22f), track fittings, installation instructions, and weight and balance data, etc. Divan is delivered in "green" ready to be finished condition, without upholstery.

**Model:** All King Air Models

**Options:** Close out, Storage Drawers, Shoulder Harness Kit

**Features:** Divan kits include, seat belts (TSO-C22f), track fittings, installation instructions, and weight and balance data, etc.

**Approvals:** Federal Aviation Administration Parts Manufacture Approval (PMA) and Supplemental Type Certificate (STC). This eliminates the need for field approval.

**STC:** SA4157SW **EASA:** 10032903 **CANADA:** M 5010-38-SA4157SW **MEXICO:** IA-371-2016 **JAPAN:** JCAB STC-179-HQT

**Installation:** No airframe modification is required to install the divan other than removing existing seat/s and furnishings, and putting the new divan in the desired location (complete installation instructions, diagrams, and weight and balance data are included in the kit). There are instances where a shoulder harnesses will be mounted to the sidewall of the airplane. This is dependent on the serial number of the airplane and will be assessed by AvFab's engineering team.

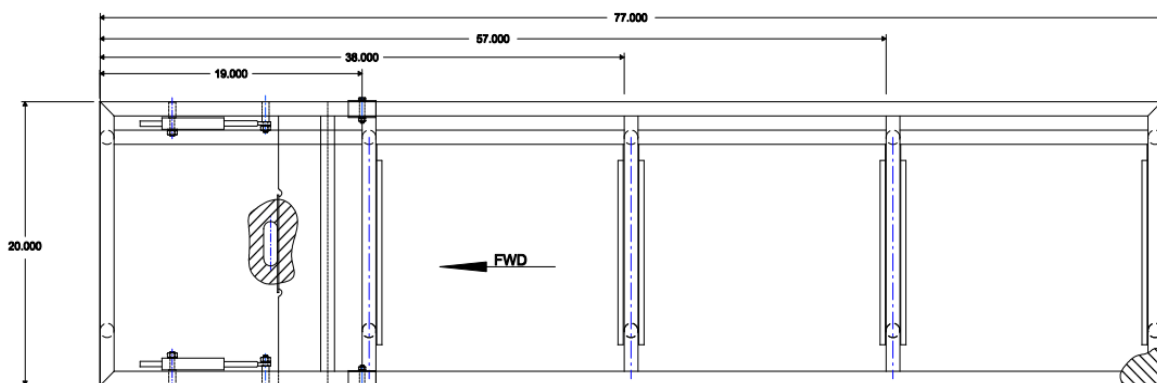



**AVIATION FABRICATORS**

805 N FOURTH ST.

CLINTON, MO 64735

(660) 885 - 8317

[SALES@AVFAB.COM](mailto:SALES@AVFAB.COM)