

King Air Divans

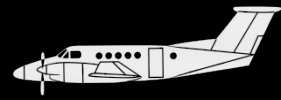

OVER 25 YEARS OF AVIATION PASSION



1-Place Divans



**AvFab 1 PAX King Air Divans have
Side-by-side versatility!**

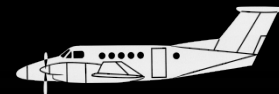

1-Place Divans

Description: AvFab's one place King Air side facing divan is extremely versatile. Can be installed alone or several can be placed alongside each other. Divans provide a modern, open and comfortable atmosphere. In many cases, this will allow you to accommodate additional passengers. Divan is delivered in "green" condition, without upholstery.

Models: Beechcraft King Air 90, 100, 200, 300, 350, 350i

FAA / STC: SA4157SW **EASA:** IA-371-2016

Approval: Federal Aviation Administration Parts Manufacture Approval, PMA, and Supplemental Type Certificate, STC, (eliminating the need for field approval).

Features: Seat includes lap belt, life vest pouch, and cushions (un-upholstered). Various floor plans are available.

Options: Square Tube Divan available 10-14" in height.

Installation: No airframe modification is required to install the divan other than removing existing seat/s and furnishings, and locating the new divan in the desired location (complete installation instructions, diagrams, and weight and balance data are included in the kit). AvFab shoulder harness restraint system, part number 32-0181K, is required to install these divans. The divans can be installed on either side of the airplane in a range of stations. Typical installed Divan weight is 18 pounds. If undersea storage drawer is required, an increase of 23 pounds should be expected.

Lead Time: Divans are normally in stock and available for immediate world-wide shipment, however, fluctuations in demand may cause up to a 30 day delivery delay.

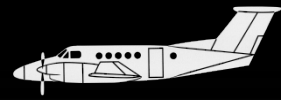

1- Place Divans Line Drawings

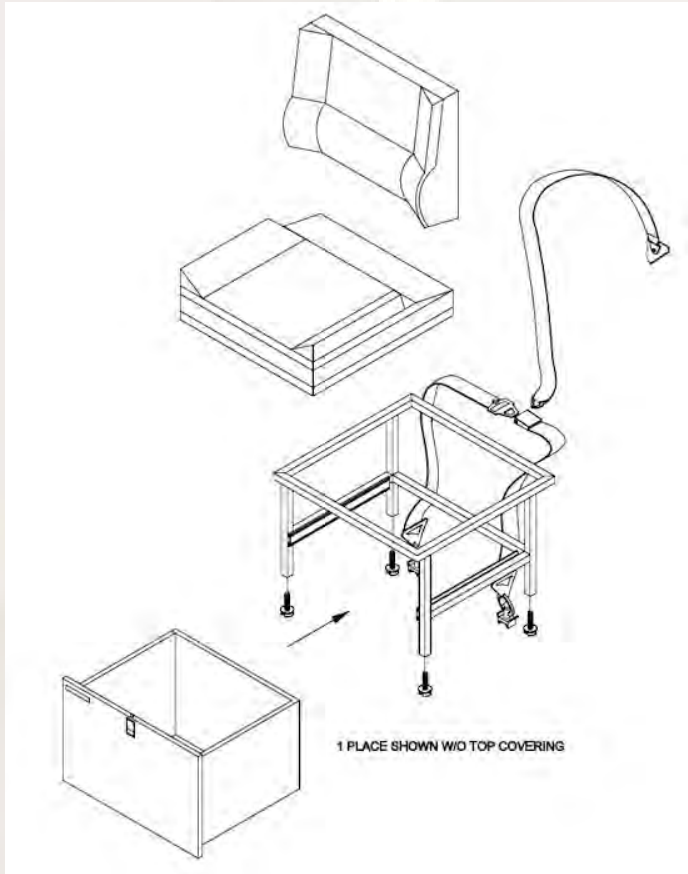

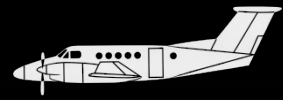

1-Place Side Facing Seat



Shown with optional Ice Tank



Shown with optional Ice Tank



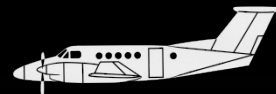

1-Place Side Facing Seat

Description: AvFab's one place King Air Side Facing Seat is extremely versatile as it allows the forward facing RH seat to recline on KA90's while saving weight over OEM seat. The included shoulder harness adds a margin of safety over the OEM seat. AvFab's Side Facing seat has a more modern appearance and is more comfortable because it has a larger seating surface than the OEM seat. In many cases, the Side Facing Seat will allow you to carry an additional passenger. Seat is delivered in "green" condition, without upholstery.

Models: Beechcraft King Air 90, 100, 200, 300, 350, 350i

FAA / STC: SA4157SW **EASA:** IA-371-2016

Approval: Federal Aviation Administration Parts Manufacture Approval, PMA, and Supplemental Type Certificate, STC, (eliminating the need for field approval).

Features: Seat includes lap belt, shoulder harness kit, life vest pouch, and cushions (un-upholstered). Various floor plans are available.

Options: Side Facing Seats are typically outfitted with the under seat stowage drawer and installed as an "Aisle-facing storage seat" across from the entry door. Optional Shoulder Harness Kit and Ice Tank are available.

Installation: No airframe modification is required other than removing existing seat/s and furnishings, and setting the new 1 place seat in the desired location (complete installation instructions, and diagrams are included in the kit). The seat can be installed on either side of the airplane in a range of stations. Seat legs are 12 inches in height and the weight is 18 pounds. If under seat storage drawer is required, an increase of 23 pounds should be expected. Optional Ice Tank will add 3 pounds.

Lead Time: Side Facing Seats are normally in stock and available for immediate world-wide shipment, however, fluctuations in demand may cause up to a 30 day delivery delay.

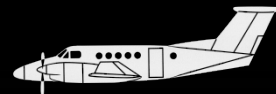

1-Place Side Facing Seat Line Drawing

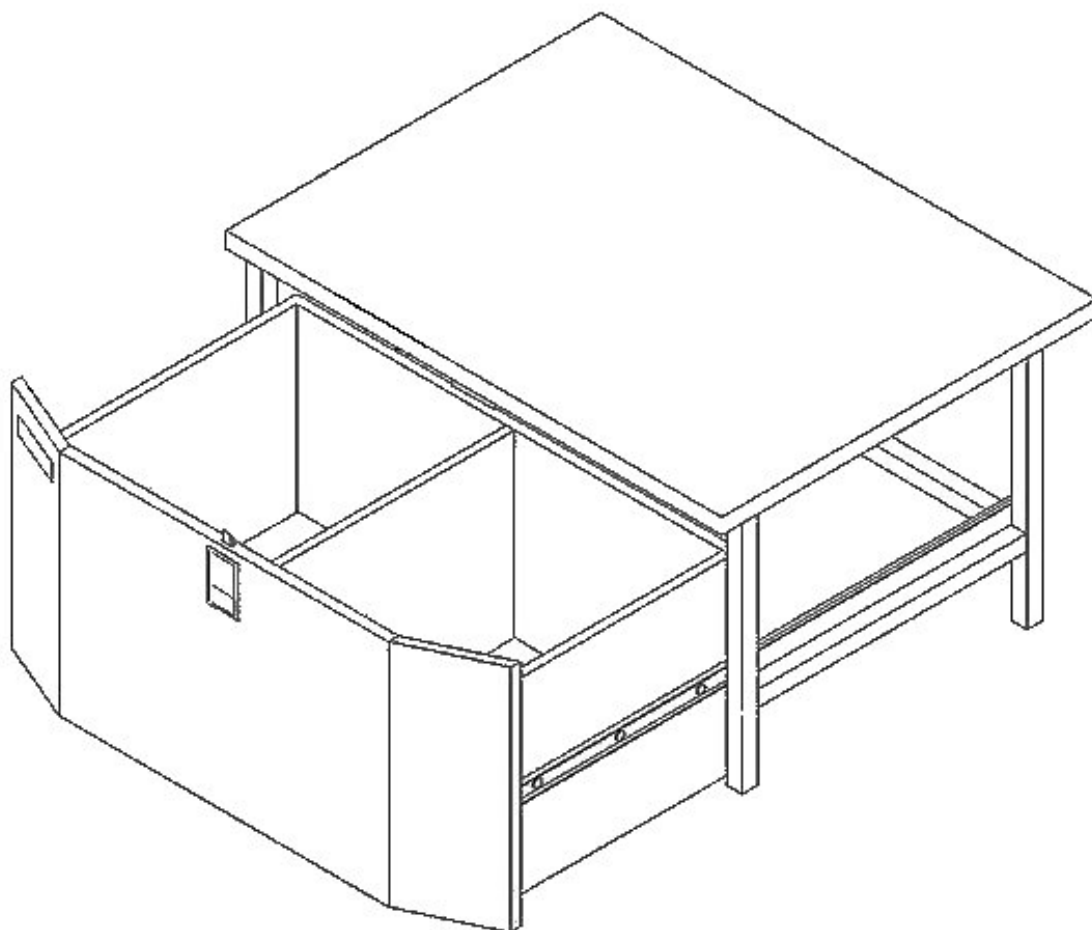



2-Place Divans



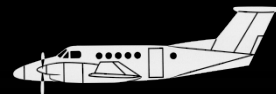

2-Place Medical Attendant Divans



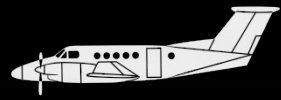

2-Place Attendant Divan





Lateral Tracking 2-Place Attendant Divan





Divan Line Drawings



2-Place Divan

Lateral Tracking 2-Place Divan

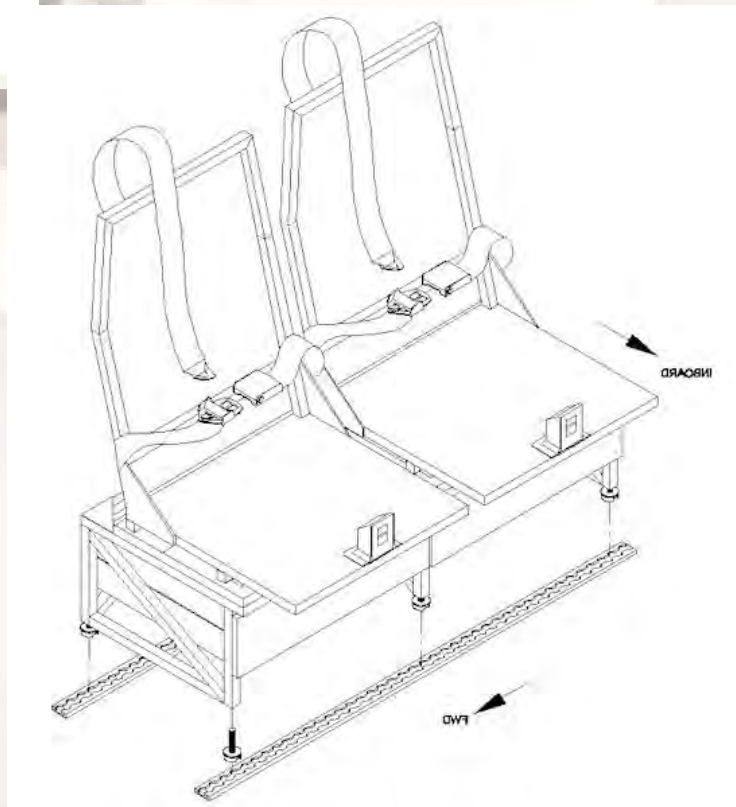

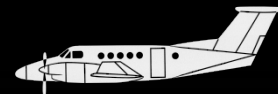

2-Place Divans

Description: Our 2-Place King Air Divan is also popular for medical attendant and Special Missions applications. In some cases you to accommodate additional passengers. Divans kits include: seat belts (TSO-C22f), track fittings, installation instructions, and weight and balance data, etc. Divan is delivered in "green" condition, without upholstery. AvFab's Two Place Lateral Tracking Divan is ideal for medical attendant use as it allows caregivers to adjust seat for closer access to patient while remaining in the restraint system.

See more at <http://avfab.com/king-air-100-200-300-350-90-2-place-divan> or <http://avfab.com/king-air-100-200-300-350-90-2-place-lateral-tracking-divan-lh>

Models: Beechcraft King Air 90, 100, 200, 300, 350, 350i

FAA / STC: Covered by one or more of the following:
 SA2630CE, SA2631CE, SA2632CE,
 SA2633CE

Options: Under seat storage drawers. Shoulder harness kit (required for this installation).

Features: Divan kits include, seat belts (TSO-C22f), track fittings, installation instructions, and weight and balance data, etc.

Installation: No airframe modification is required to install the divan other than removing existing seat/s and furnishings, and locating the new divan in the desired location (complete installation instructions, diagrams, and weight and balance data are included in the kit). AvFab shoulder harness restraint system, part number 32-0181K, is required to install these divans. See shoulder harness data sheet for installation instructions. The divans can be installed on either side of the airplane in a range of stations.

Lead Time: Typical lead time for these divan/stretchers is 14 days after receipt of purchase order. However, fluctuations in demand may cause up to a 30 day delivery delay.



4-Place Recline- Divan



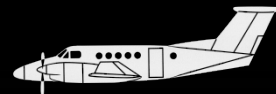

4-Place Recline-Divan



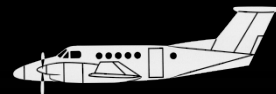

4-Place Stretcher-Divan



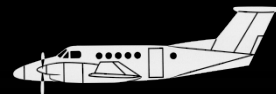

4-Place Stretcher-Divan

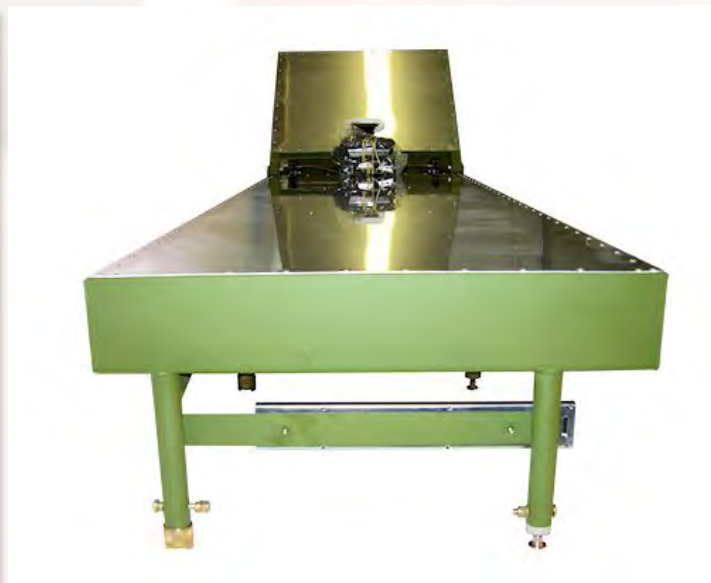

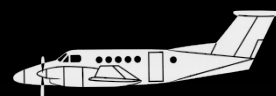

4-Place Recline & Stretcher Divans

Description: Increase the utility and functionality of your King Air with an AvFab 4 place Divan/Stretcher that allows you the option of carrying either passengers or a patient on the same divan. This conversion can easily be done with the divan/stretcher still in the aircraft. The Divan/Stretcher is approved for occupancy during all phases of flight (including takeoff and landing).

See more at <http://avfab.com/king-air-100-200-300-90-stretcher-divan-4-place-rh>

Models: Beechcraft King Air 90, 100, 200, 300, 350, 350i

FAA / STC: Covered by one or more of the following:
SA2630CE, SA2631CE, SA2632CE, SA2633CE

Options: Under seat storage drawers.
Shoulder harness kit (required for this installation).

Features: Very quickly and easily converted between passenger carrying and for patient transportation. You can carry passengers on one leg of a flight and then convert it for an ambulatory person on the next leg. FAA approved for either use.

Installation: No airframe modification is required to install the divan other than removing existing seat/s and furnishings, and locating the new divan in the desired location (complete installation instructions, diagrams, and weight and balance data are included in the kit). AvFab shoulder harness restraint system, part number 32-0181K, is required to install these divans. See shoulder harness data sheet for installation instructions. The divans can be installed on either side of the airplane in a range of stations.

Lead Time: Typical lead time for these divan/stretchers is 14 days after receipt of purchase order. However, fluctuations in demand may cause up to a 30 day delivery delay

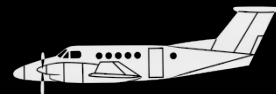

4-Place Stretcher-Divan Line Drawing

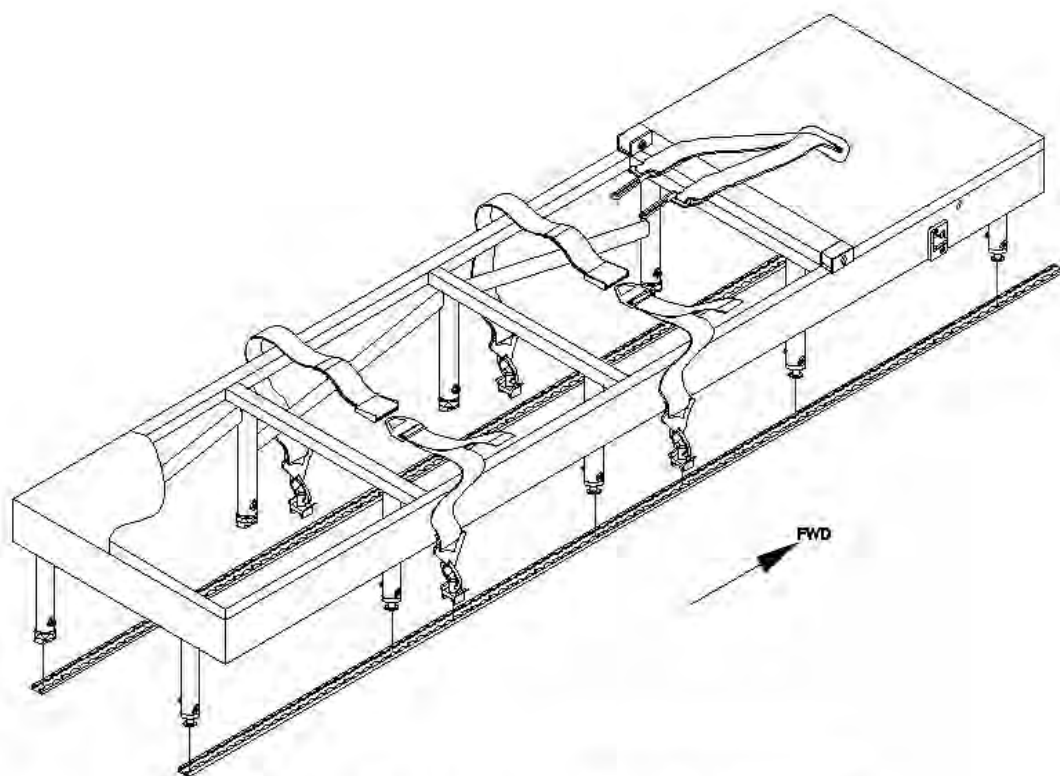

LH ASSEMBLY WITH STRETCHER RESTRAINTS



Learn more about Avfab's comprehensive line of
King Air products & services at:

www.AvFab.com

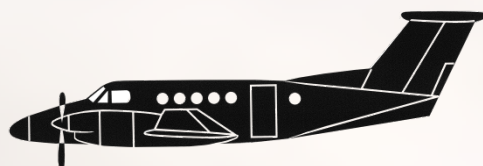
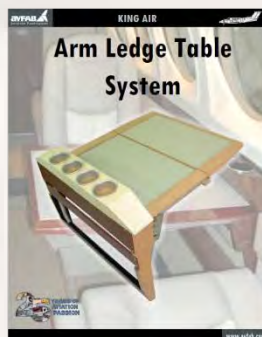

Aviation Fabricators

805 North 4th Street

Clinton, MO 64735

(660) 885-8317

www.AvFab.com