

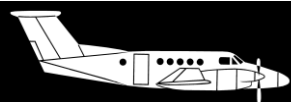

Intelligence, Surveillance & Reconnaissance

Operator Seats

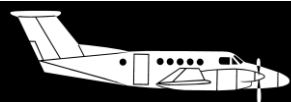

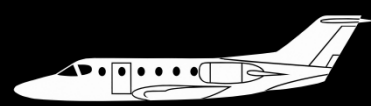



ISR Operator Seat Details

Description: AvFab devotes considerable attention toward supporting Special Missions and ISR (Intelligence, Surveillance, and Reconnaissance) aircraft seating needs. These products include developing the Beechjet Special Mission Observer / Operator's Seat for the US military's T1A "Jayhawk". The King Air Operator Seat was born from our success with the Beechjet Operator Seat. AvFab's STC approved King Air Operator Seat provides a proven design that is well-suited for the demanding requirements of any Special Missions ISR theater, while weighing in at only 33.0 lbs. (37.0 lbs. with optional upholstery). Maximum operator comfort is ensured from design features that include vertical seat adjustment of 3" and fore-aft floor tracking controlled via convenient hand levers, 5-point restraint system, and stowable arm rests.

Models: Beechcraft King Air 90, 100, 200, 300, 350, 350i (MC-12) & Beechjet 400 (T1A Jayhawk)

FAA / STC: STC SA01809WI & EASA 10066088 (King Air only)
 Beechjet requires 8110-3 Field Approval

Features: The AvFab King Air Operator Seat features "Top Access" installation which allows the seat to be installed directly from above the seat track eliminating the time and cost other seats require to clear the seat track of consoles or other equipment to install the seat. The robust design is well-suited for the demanding requirements of any ISR theater, weighing in at only 28.5 pounds. Additional features include vertical seat adjustment of 5.0" of travel, 5-point restraint system, stowable arm rests, and floor-tracking. An aft-tracking version is in development and should be available soon.

Options: Folding/Stowable Armrests, Leather Upholstery, Sheepskin Seating Surfaces

Installation: Our King Air ISR Operator seat installs easily from above the seat track utilizing the existing style King Air seat track. Beechjet ISR Operator Seats mount on the OEM Brownline track. No airframe modification is required to make the installation.

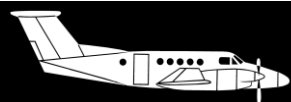

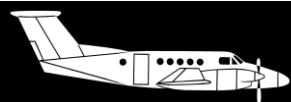
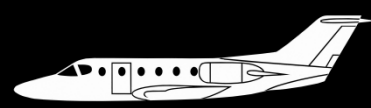

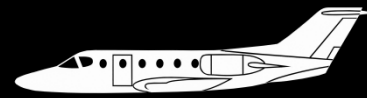

Operator ISR Seat Detail Drawings

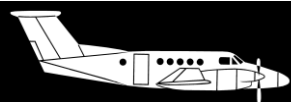
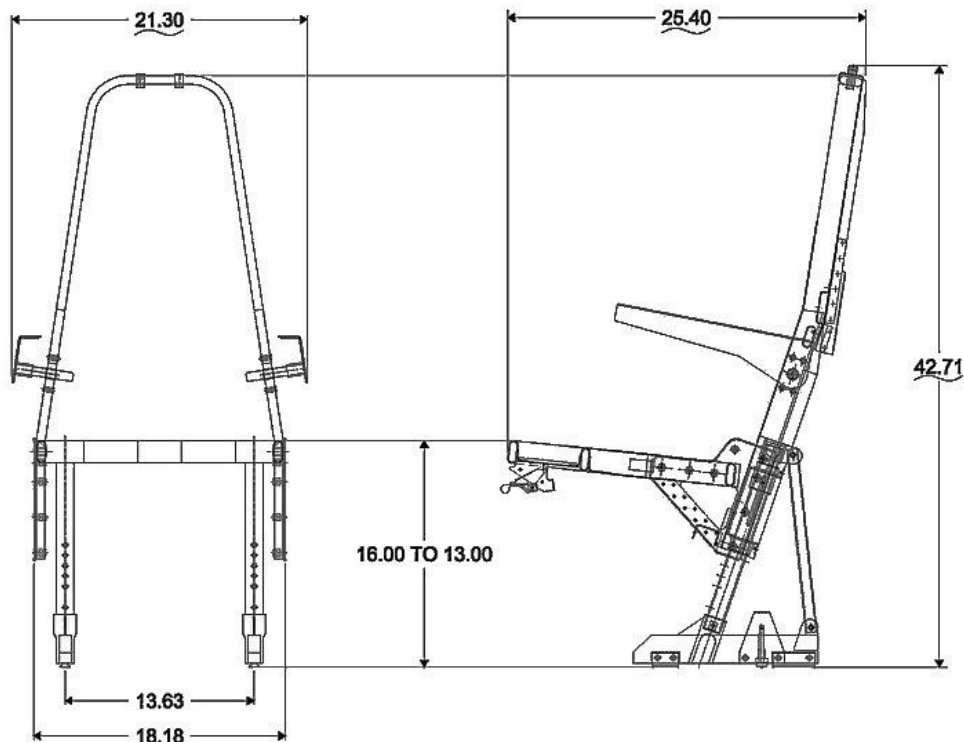
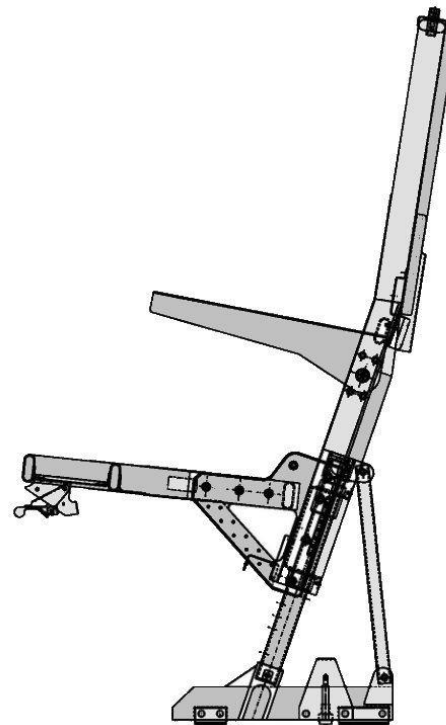
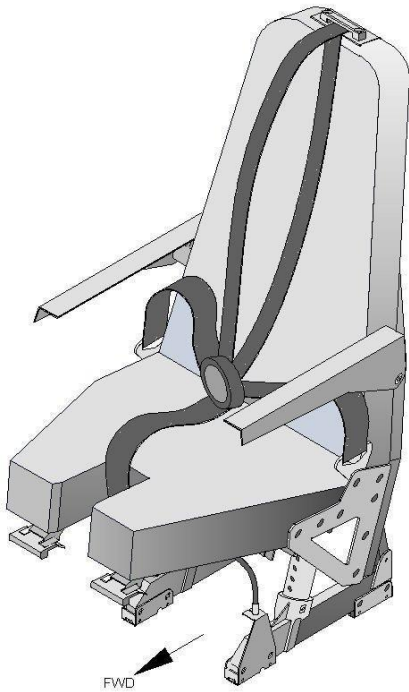

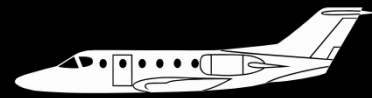

KING AIR TOP ACCESS DETAIL

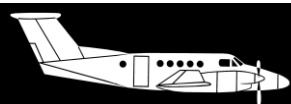

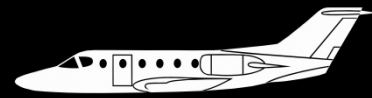

Learn more about Avfab's comprehensive line of Special Missions products & services at www.AvFab.com



Aviation Fabricators
805 North Fourth Street
Clinton, MO 64735
(660) 885-8317
www.AvFab.com

