

REGAL™ Pleated Window Shades

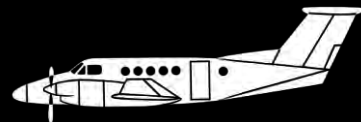



Our Regal™ Pleated Shade Material features:

- Low / no emission production process
- No toxic content
- Flame retardant
- No toxic smoke / gases during fire.
- Anti-bacterial coating
- Excellent sun protection:
 - Light transmission as low as 4%
 - Heat reflection up to 75% (direct)
- Insulation reduction of heat loss 20%.



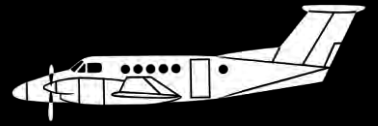

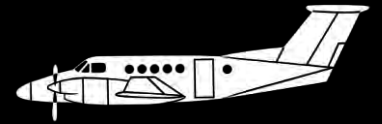

REGAL WINDOW SHADES KEEP YOUR KING AIR CABIN OVER 10°F COOLER ON THE RAMP!

Our real world tests show that AvFab Regal Pleated Window Shades reduced the difference between cabin and ambient temperature an average of 60%



Learn more at www.AvFab.com



AvFab Regal™ Pleated Window Shades reduced the difference between cabin and ambient temperature an average of 60%

CABIN TEMP RAMP TEST

King Air C90 with Cockpit/Cabin Divider open both days

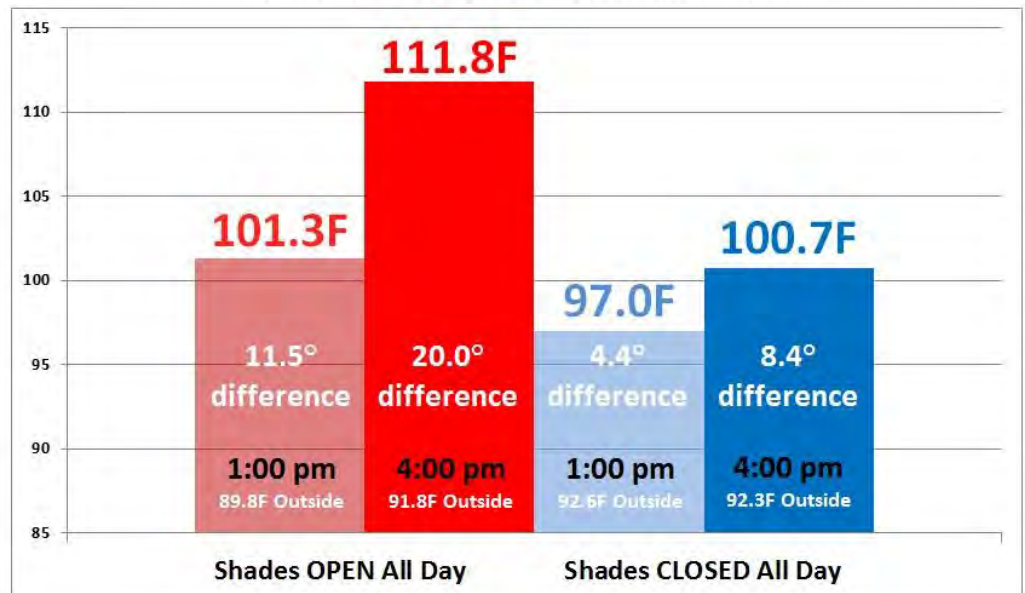

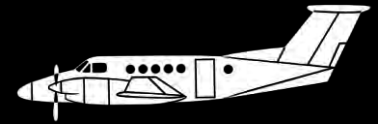

RegalTM Pleated Window Shades

Description: Update your King Air 90, 200, 300/350 series with AvFab's STC approved "Regal" Pleated Window Shades which replace the OEM Polarizers. Unlike OEM Polarizers that must remain in the open (clear) position on the ramp allowing full sunlight into the cabin, AvFab Regal Pleated Window Shades can be left closed on the ramp, dramatically lowering cabin temps while your King Air is parked. Regal Pleated Shades update your King Air interior with the contemporary look that executive jets have and are designed for long term, smooth operation with an industry leading full 24-month warranty!

Model: 90, 200, 300/350

Options: Available in four "Regal" colors (Gray, Tan, Olivine, Limestone) to compliment any interior. Free color swatches upon request.

Features: AvFab STC approved Pleated Window Shades offer attractive and durable pleated material. The frame mechanism is engineered for smooth, non-binding operation. Regal shades also provide excellent sun protection, as low as 4% light transmission, and heat reflection up to 75% resulting in less sun damage to your interior. They have insulating properties with a reduction of heat loss of 20%.

Approvals: FAA STC and PMA eliminating the need for field approval for 90 & 200 series. Other models require 8110-3.

FAA STC: SA01672WI (90, 200, 300/350) **Canada:** M5012-38-SA1672WI (200 only)
EASA: 10061033 (200 only)

Installation: Kit includes everything necessary to convert the aircraft from Polarizers to the AvFab window shades. Regal shades weigh slightly less than the OEM shades. The 90 Series requires an LED lighting upgrade (available at www.pwi-e.com) for clearance. Once the Polarizers are removed, install the AvFab window shades using the same mounting attachments. Kit is complete with everything needed for the installation, including comprehensive installation instructions. Installation time is approximately 2.5 hours per shade, depending on the experience of the technician. King Airs that have the overhead light bulbs attached to the window line/headliner panels will have no problem. If the light bulb fixture is mounted to the airframe, it will have to be relocated. The airframe-mounted light fixture is typically found in the earliest models up through 1978, and also includes a few 1979 models. Installation time KA300 – 35 hours per ship set, B300 (KA350) – 45 hours per ship set depending on the installation facility's experience-level with window shades.

Lead Time: In stock normally 3 days. If custom built, expect 10 to 20 working days.

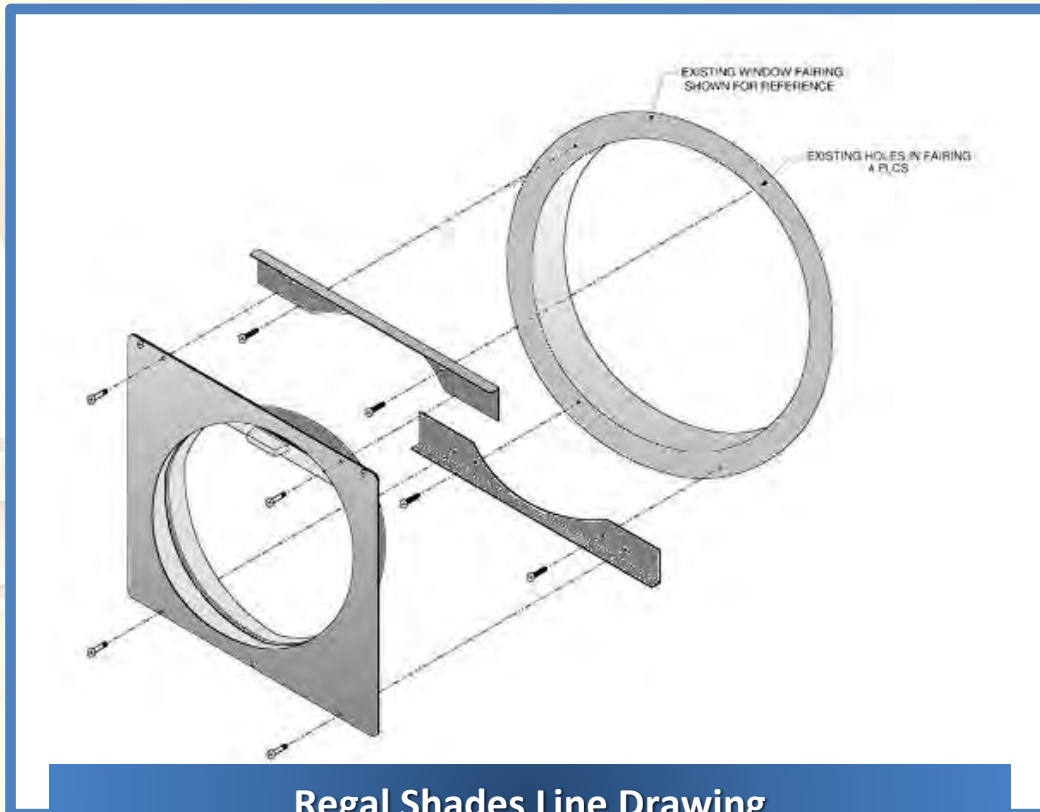
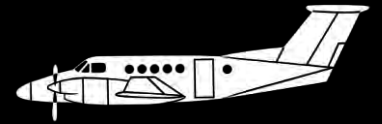

Regal Shades Line Drawing



Regal Shades shown in a King Air KA90 with PWI's LED Lighting

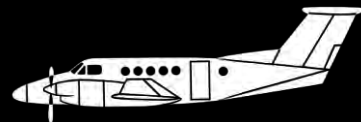

Contact AvFab for a
free swatch of our
Regal Pleated Shade
Material at:
660.885.8317 or
sales@avfab.com

Aviation Fabricators
805 North 4th Street
Clinton, MO 64735
660-885-8317
www.avfab.com
jlowe@avfab.com

King Air
Window Shade Color Samples

(000) Gray

(292) Olivine

(741) Tan

(221) Limestone

avFAB
AVIATION FABRICATORS
avfab.com

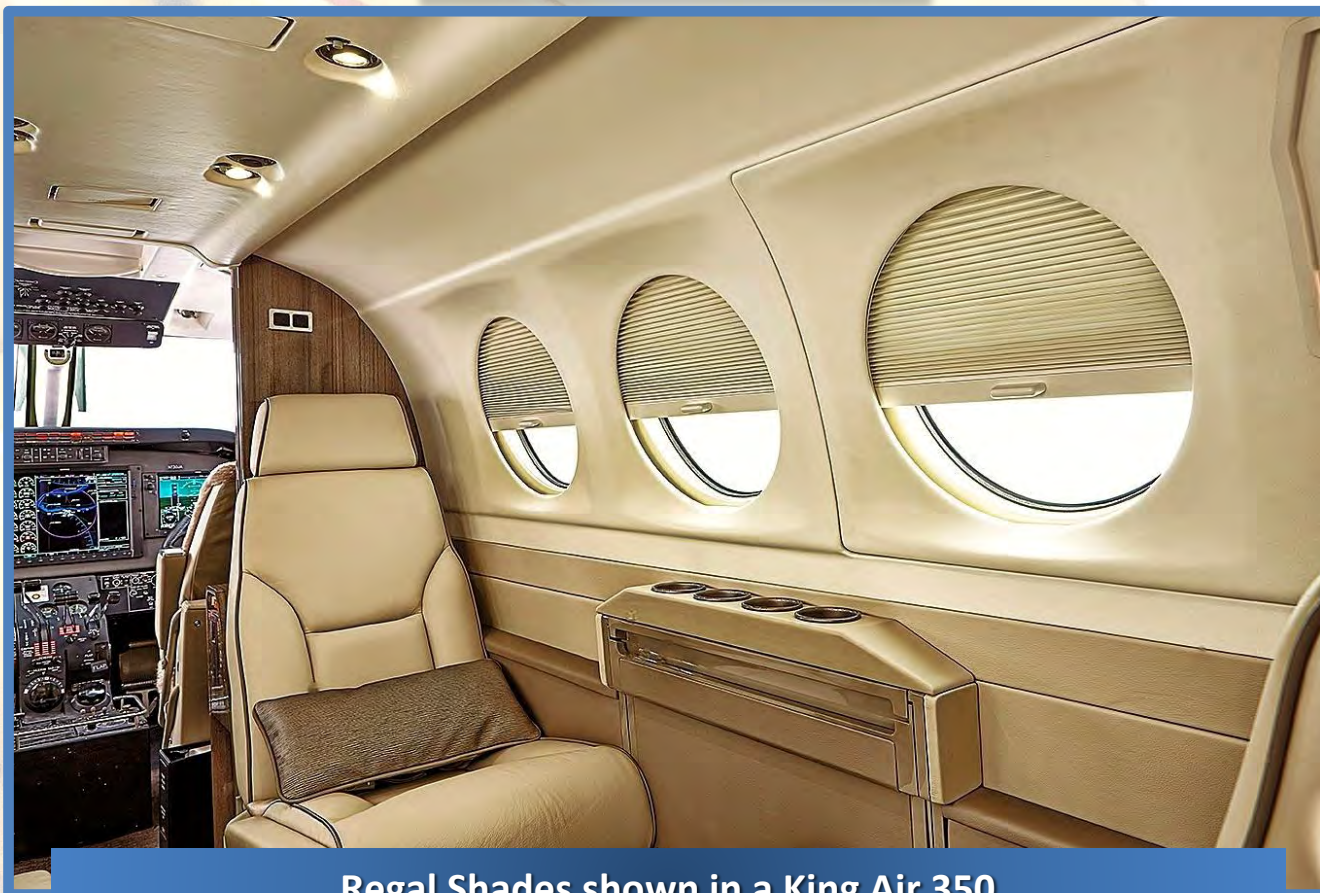

Regal Shades shown in a King Air 350

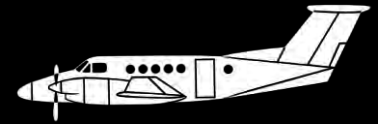

Learn more about Avfab's comprehensive line
of King Air products & services at
www.AvFab.com

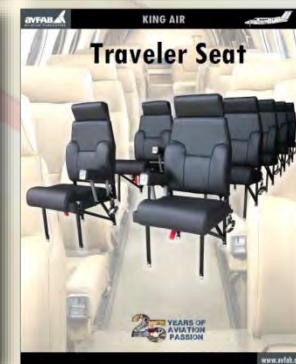
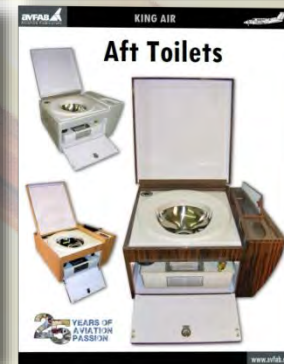
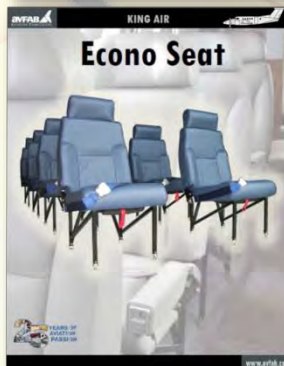
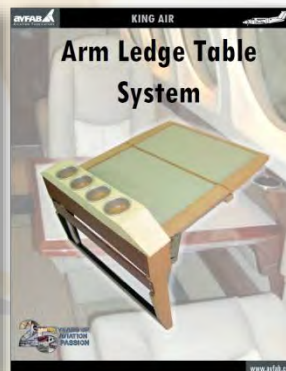

Aviation Fabricators
805 North 4th Street
Clinton, MO 64735
(660) 885-8317