

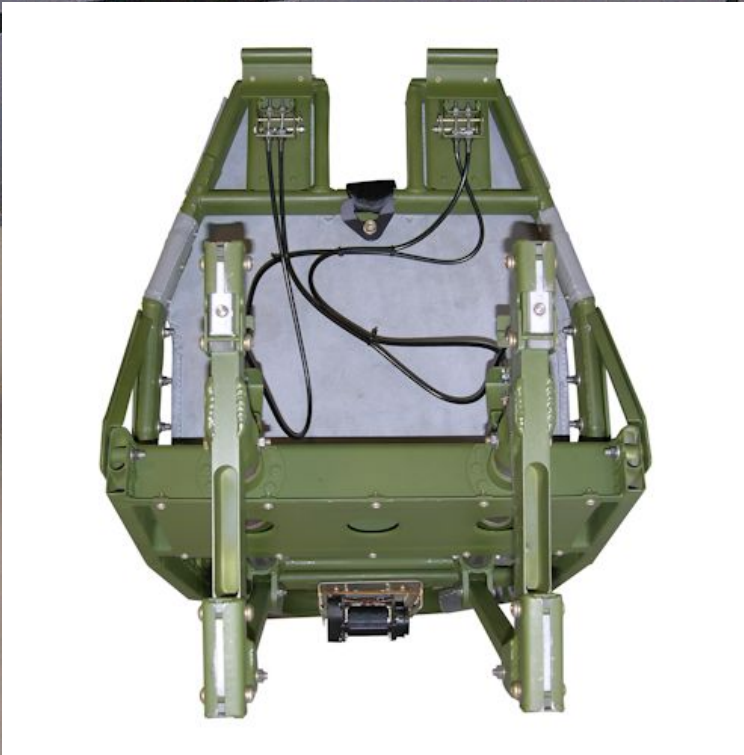

Intelligence, Surveillance & Reconnaissance

# Operator Seats

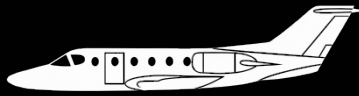



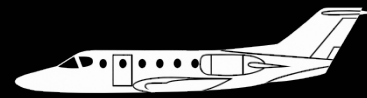

# Operator ISR Seat Details

**Description:** AvFab devotes considerable attention toward supporting Special Missions and ISR (Intelligence, Surveillance, and Reconnaissance) aircraft seating needs. These products include developing the Beechjet Special Mission Observer / Operator's Seat for the US military's T1A "Jayhawk". The King Air Operator Seat was born from our success with the Beechjet Operator Seat. AvFab's STC approved King Air Operator Seat provides a proven design that is well-suited for the demanding requirements of any Special Missions ISR theater, while weighing in at only 33.0 lbs. (37.0 lbs. with optional upholstery). Maximum operator comfort is ensured from design features that include vertical seat adjustment of 3" and fore-aft floor tracking controlled via convenient hand levers, 5-point restraint system, and stowable arm rests.

**Models:** Beechcraft King Air 90, 100, 200, 300, 350, 350i (MC-12) & Beechjet 400 (T1A Jayhawk)

**FAA / STC:** STC SA01809WI (King Air models), Beechjet requires 8110-3 Field Approval

**Features:** The AvFab Operator Seat provides a robust design that is well-suited for the demanding requirements of any ISR theater, weighing in at only 28.5 pounds. Our King Air Operator Seat installs easily from above the seat track. This feature eliminates the time and cost other seats require to clear the seat track of consoles or other equipment to install the seat. Additional features packed into this design include vertical seat adjustment of 5.0" of travel, 5-point restraint system, stowable arm rests, and floor-tracking. An aft-tracking version is in development and should be available soon.

**Options:** Folding/Stowable Armrests, Leather Upholstery, Sheepskin Seating Surfaces

**Installation:** Our King Air ISR Operator seat installs easily from above the seat track utilizing the existing style King Air seat track. Beechjet ISR Operator Seats mount on the OEM Brownline track. No airframe modification is required to make the installation.



## WE ARE MISSION READY!



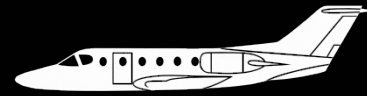

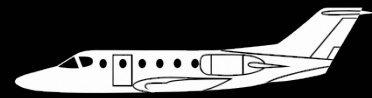

## Operator ISR Seat Line Drawings

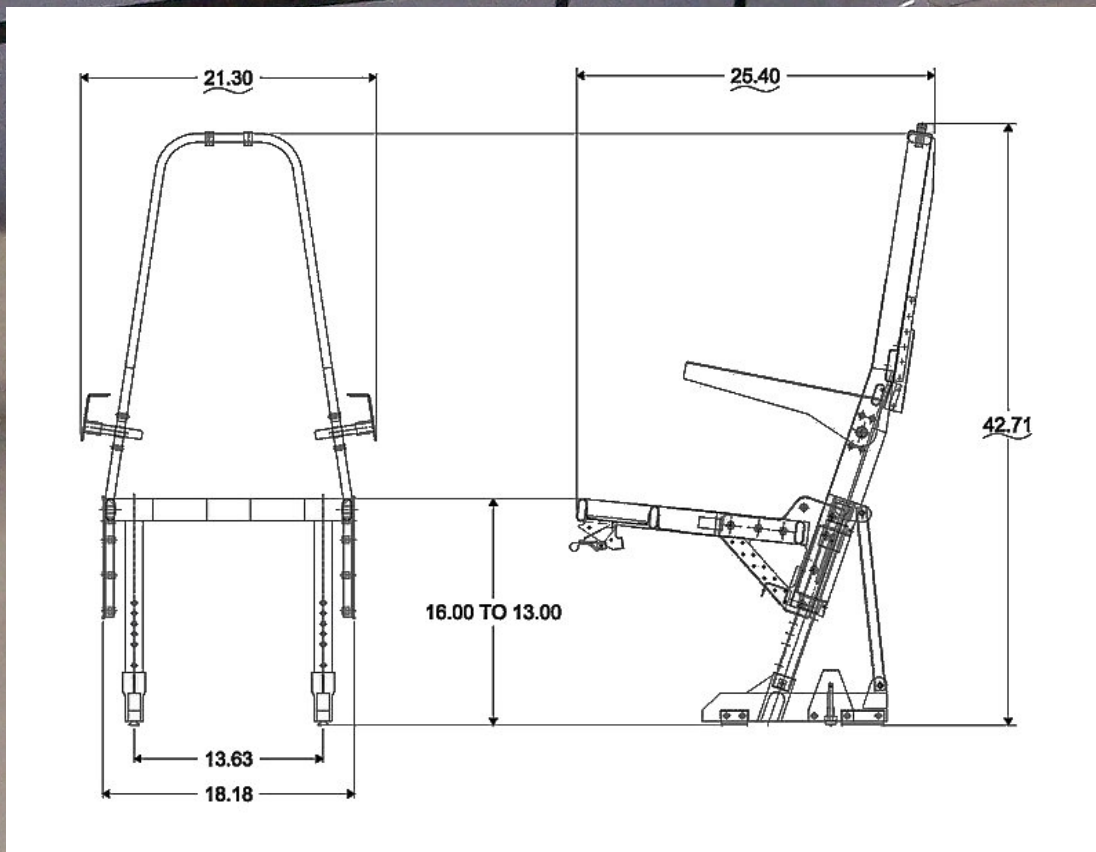
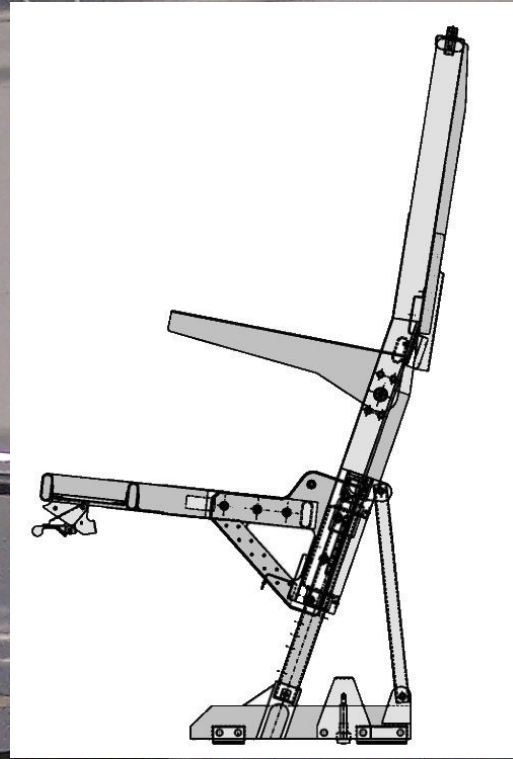
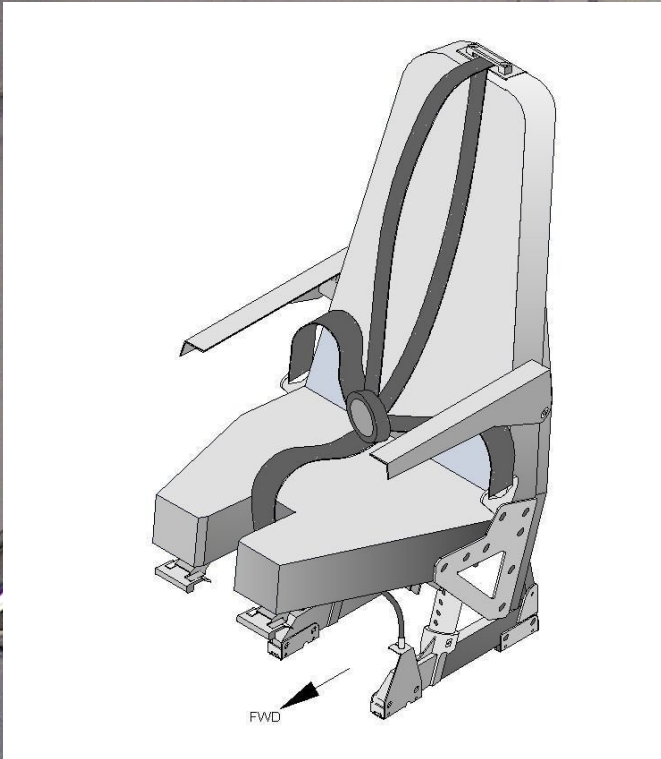

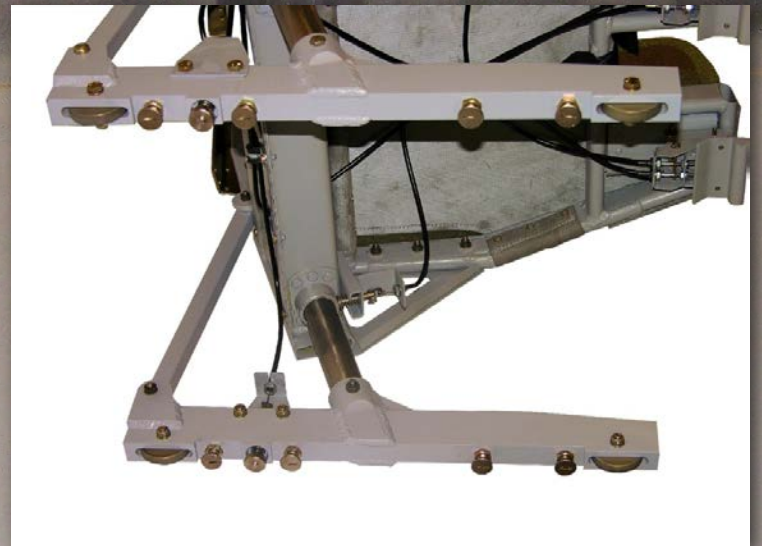
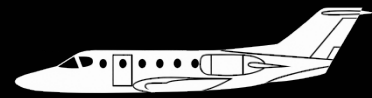

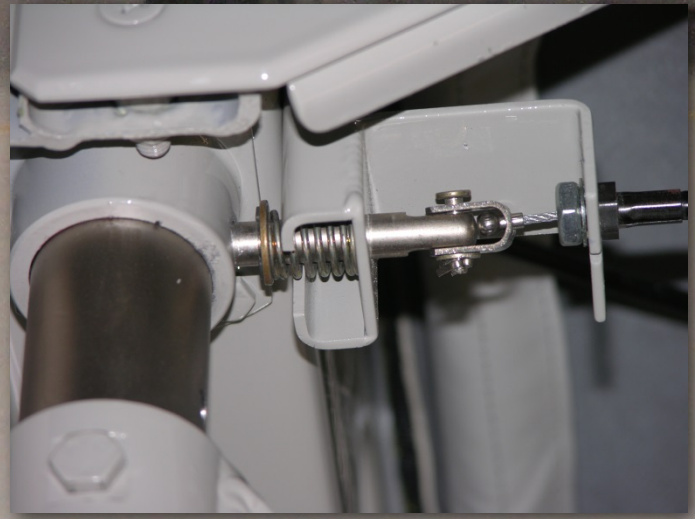
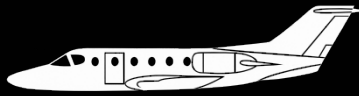

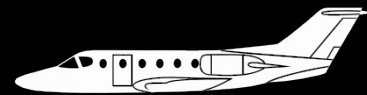

Learn more about Avfab's comprehensive line of Special Missions products & services at [www.AvFab.com](http://www.AvFab.com)



**Aviation Fabricators**  
805 North Fourth Street  
Clinton, MO 64735  
(660) 885-8317  
[www.AvFab.com](http://www.AvFab.com)

