



# Lateral Tracking Seat Bases & Divan Catalog





## **Lateral Tracking Seat Base**





# Lateral Tracking Seat Base Data

**Description:** Now there is no need to spend exorbitant amounts of money on aftermarket seats! We have a kit that was designed to allow passengers to track laterally, effectively gaining a 3.5" of side clearance (and proportionate head room clearance) advantage over the OEM seats. This is accomplished by installing our Lateral Tracking Base on an existing factory seat. This modification is typically done in the field, and does not require re-covering the modified seat.

**Models:** 90, 100, 200

**Options:** Base can be painted to match color.

**Features:** Lateral Tracking Seat Base improves Passenger Head Room and Side Panel Clearance for greater in flight comfort while retaining factory seat and appearance.

**Approvals:** FAA STC and PMA eliminating the need for field approval.

**STC:** SA00453WI

**Installation:** The kit comes complete with all hardware and comprehensive instructions. After the new base is painted to the desired color and the existing base is removed, the lateral tracking base can be installed in less than 1 hour.

**Lead Time:** Lateral Tracking Seat Bases are normally in stock, however, fluctuations in demand may cause up to a 30 day delivery delay.

**Trade In:** Item can be sold as an outright or exchange purchase. Typically, the replaced non-lateral tracking base is traded in.

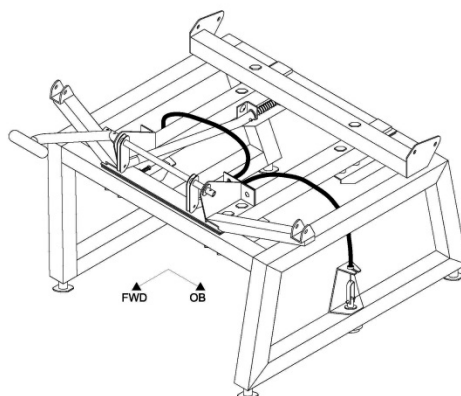





# Lateral Tracking Divan





# Lateral Tracking Divan



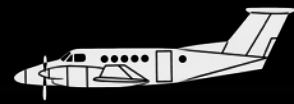

## Lateral Tracking Divan Line Drawings

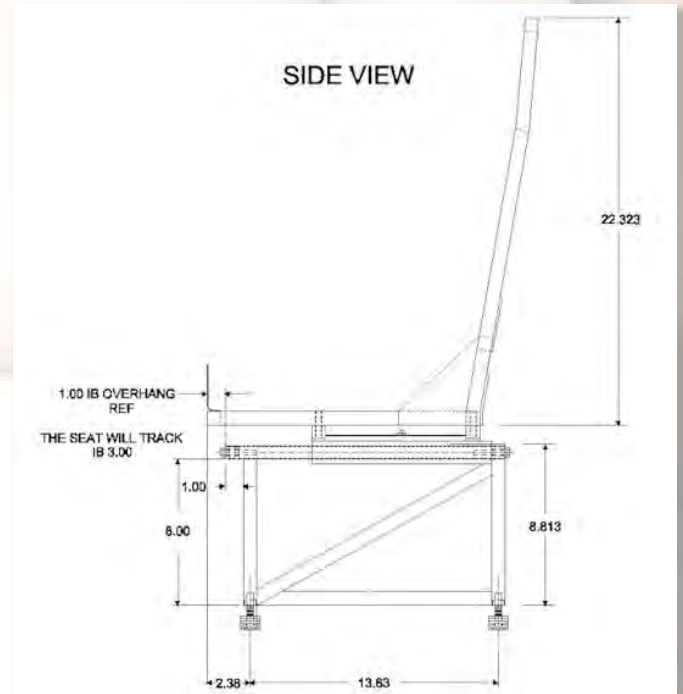
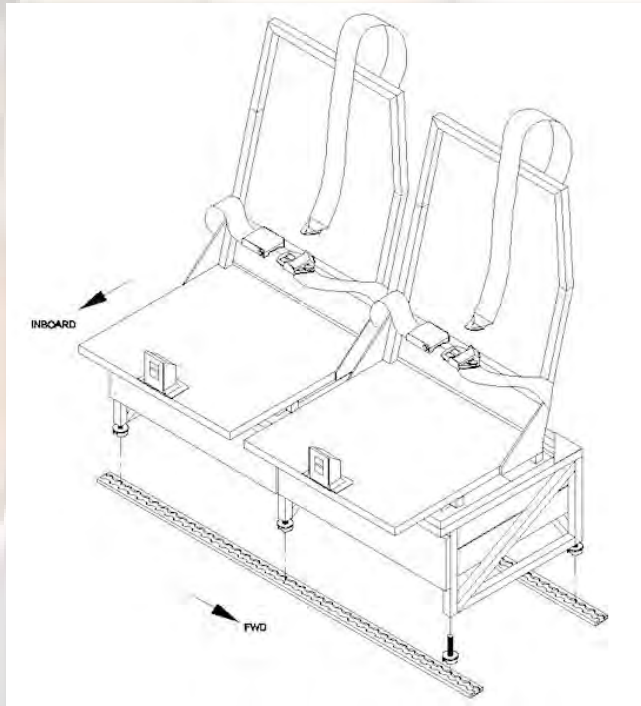





# Lateral Tracking Divan Data

**Description:** AvFab's Two Place Lateral Tracking Divan is ideal for medical attendant use as it allows caregivers to adjust seat for closer access to patient while remaining in the restraint system.

**Models:** 90, 100, 200, 300, 350

**Options:** Drawers, Armrests

**Features:** AvFab Lateral Tracking Seat Base improves Passenger Head Room and Side Panel Clearance for greater in flight comfort while retaining factory seat and appearance.

**Approvals:** Federal Aviation Administration Parts Manufacture Approval, PMA, and Supplemental Type Certificate, STC, (eliminating the need for field approval).

**STC:** FAA SA4157SW  
EASA: 10032903

**Installation:** No airframe modification is required to install the divan other than removing existing seat/s and furnishings, and locating the new divan in the desired location (complete installation instructions, diagrams, and weight and balance data are included in the kit).

**Lead Time:** Lateral Tracking Divans are normally in stock, however, fluctuations in demand may cause up to a 30 day delivery delay.

**Trade In:** Please contact us for a quote.



Learn more about Avfab's comprehensive line  
of King Air products & services at  
[www.AvFab.com](http://www.AvFab.com)



## Aviation Fabricators

805 North 4th Street

Clinton, MO 64735

(660) 885-8317

[www.AvFab.com](http://www.AvFab.com)